

FAST SINGLE SHAFT SHREDDER PROMECO KRF

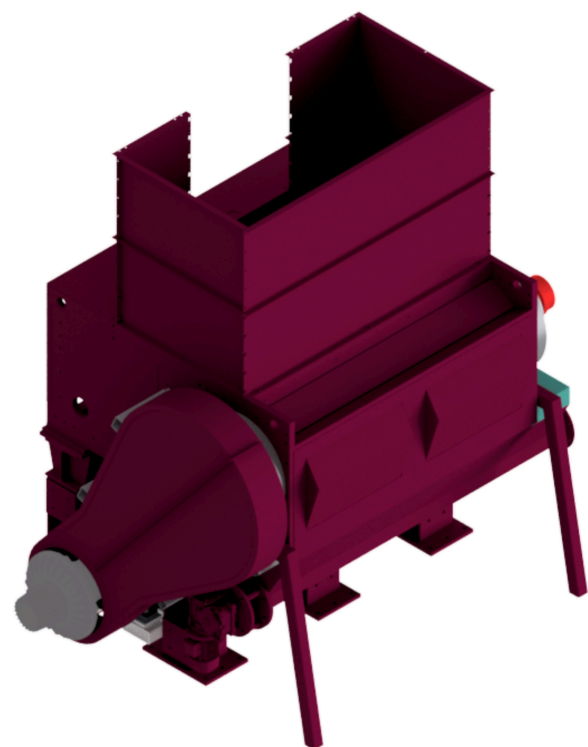

KRF shredders, as for KR, are characterized by strength, versatility, reliability, high production performance with reduced operation and management costs as well as ease of maintenance.

KRF Shredder is a fast shredder that reaches 330 rpm and reduces the mid-hardness materials in volume through an optimized cutting process that, due to the lower position of the pusher towards the rotor axis, allows optimal productions with minor power installed.

TECHNICAL FEATURES

- Robustness
- Standard blades easy to be found on the market
- Optimized cutting system
- Reliability
- Versatility
- Ease of maintenance
- Customizable machine

INPUT MATERIAL

- RDF, RPF, SSF
- Plastic
- Rubber
- LDPE
- HDPE
- PP
- Densified plastic



OUTPUT MATERIAL

- Shred material sized 10-50 mm

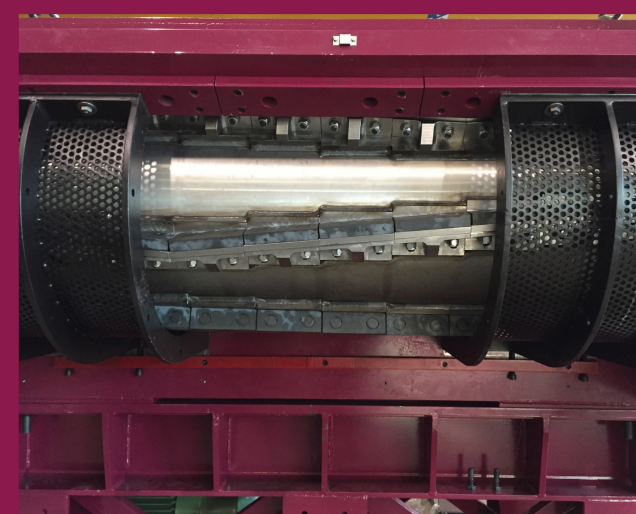

MODELS AVAILABLE

Rotor's length:
from 1000 to 3500 mm

Rotor's diameter:
from 400 to 730 mm

Power:
from 45 to 250 kW

Customized models upon request

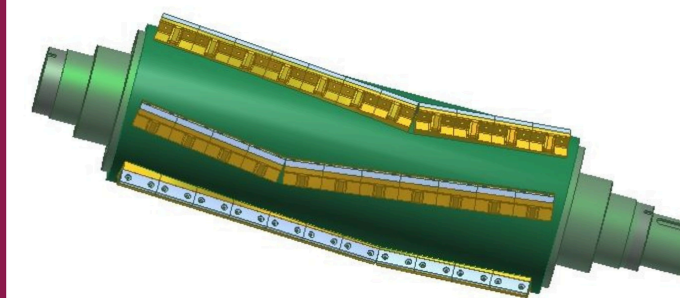

FAST ROTOR 200 - 350 rpm
FOR EASY MATERIALS
HIGH SHREDDING CAPACITY

